

# 1-Bit Bidirectional Voltage-Level Translator for Open-Drain and Push-Pull Application

## FEATURES

- **No Direction-Control**
- **Data Rates**  
**24Mbps (Push-Pull)**  
**2Mbps (Open-Drain)**
- **1.65V to 5.5V on A ports and 2.3V to 5.5V on B Ports ( $V_{CCA} \leq V_{CCB}$ )**
- **$V_{CC}$  Isolation: If Either  $V_{CC}$  is at GND, Both Ports are in the High-Impedance State**
- **No Power-Supply Sequencing Required: Either  $V_{CCA}$  or  $V_{CCB}$  can be Ramped First**
- **$I_{OFF}$ : Supports Partial-Power-Down Mode Operation**
- **Extended Temperature:  $-40^{\circ}\text{C}$  to  $+85^{\circ}\text{C}$**

## APPLICATIONS

- **I<sup>2</sup>C/ SMBus**
- **UART**
- **GPIO**

## DESCRIPTION

This 1-bit non-inverting translator is a bidirectional voltage-level translator and can be used to establish digital switching compatibility between mixed-voltage systems. It uses two separate configurable power-supply rails, with the A ports supporting operating voltages from 1.65V to 5.5V while it tracks the  $V_{CCA}$  supply, and the B ports supporting operating voltages from 2.3V to 5.5V while it tracks the  $V_{CCB}$  supply. This allows the support of both lower and higher logic signal levels while providing bidirectional translation capabilities between any of the 1.8V, 2.5V, 3.3V and 5V voltage nodes.

When the output-enable (OE) input is low, all I/Os are placed in the high-impedance state, which significantly reduces the power-supply quiescent current consumption. OE has an internal pull-down current source, as long as  $V_{CCA}$  is powered.

To ensure the high-impedance state during power up or power down, OE should be tied to GND through a pull-down resistor; the minimum value of the resistor is determined by the current-sourcing capability of the driver.

The RS0101 is available in Green SOT23-6, SOT363(SC70-6) and DFN1.45x1.0-6L packages. It operates over an ambient temperature range of  $-40^{\circ}\text{C}$  to  $+85^{\circ}\text{C}$ .

## Functional Block Diagram

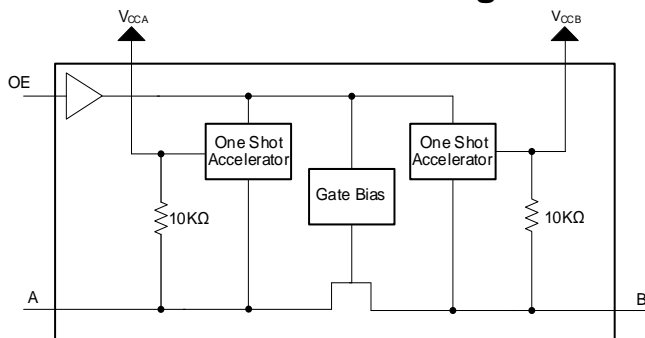

## Revision History

Note: Page numbers for previous revisions may differ from page numbers in the current version.

<b>VERSION</b>	<b>Change Date</b>	<b>Change Item</b>
A.1	2020/09/02	Initial version completed
A.2	2020/09/10	Fix mistake in PACKAGE/ORDERING INFORMATION. Order number value from RS0101YUTDV8 to RS0101YUTDV6
A.3	2021/01/09	Add Moisture Sensitivity Level information

## PIN CONFIGURATIONS

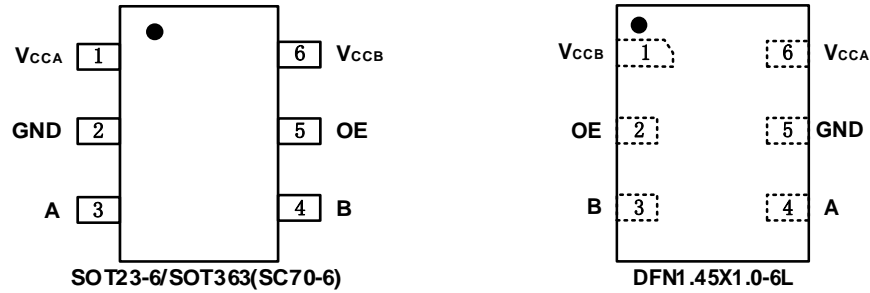

## PIN DESCRIPTION

PIN		NAME	TYPE <sup>(1)</sup>	FUNCTION
SOT23-6/ SOT363(SC70-6)	DFN1.45x1.0- 6L			
1	6	V <sub>CCA</sub>	P	A Port Supply Voltage. $1.65V \leq V_{CCA} \leq 5.5V$ and $V_{CCA} \leq V_{CCB}$ .
2	5	GND	-	Ground.
3	4	A	I/O	Input/output A. Reference to V <sub>CCA</sub> .
4	3	B	I/O	Input/output B. Reference to V <sub>CCB</sub> .
5	2	OE	I	Output Enable (Active High). Pull OE low to place all outputs in 3-state mode. Referenced to V <sub>CCA</sub> .
6	1	V <sub>CCB</sub>	P	B Ports Supply Voltage. $2.3V \leq V_{CCB} \leq 5.5V$ .

(1) I=input, O=output, I/O=input and output, P=power



## SPECIFICATIONS

### Absolute Maximum Ratings

Over operating free-air temperature range (unless otherwise noted) <sup>(1)</sup>

SYMBOL	PARAMETER	MIN	MAX	UNIT	
V <sub>CCA</sub>	Supply Voltage Range	-0.3	6.0	V	
V <sub>CCB</sub>	Supply Voltage Range	-0.3	6.0	V	
V <sub>I</sub> <sup>(2)</sup>	Input Voltage Range	A port	-0.3	6.0	V
		B port	-0.3	6.0	
V <sub>O</sub> <sup>(2)</sup>	Voltage range applied to any output in the high-impedance or power-off state	A port	-0.3	6.0	V
		B port	-0.3	6.0	
V <sub>O</sub> <sup>(2)(3)</sup>	Voltage range applied to any output in the high or low state	A port	-0.3	V <sub>CCA</sub> +0.3	V
		B port	-0.3	V <sub>CCB</sub> +0.3	
I <sub>IK</sub>	Input clamp current	V <sub>I</sub> <0		-50	mA
I <sub>OK</sub>	Output clamp current	V <sub>O</sub> <0		-50	mA
I <sub>O</sub>	Continuous output current			±50	mA
	Continuous current through V <sub>CCA</sub> , V <sub>CCB</sub> or GND			±100	mA
T <sub>J</sub>	Junction Temperature			150	°C
T <sub>stg</sub>	Storage temperature	-65	+150		

(1) Stresses beyond those listed under *Absolute Maximum Ratings* may cause permanent damage to the device. These are stress ratings only, which do not imply functional operation of the device at these or any other conditions beyond those indicated under *Recommended Operating Conditions*. Exposure to absolute-maximum-rated conditions for extended periods may affect device reliability.

(2) The input and output negative-voltage ratings may be exceeded if the input and output current ratings are observed.

(3) The value of V<sub>CCA</sub> and V<sub>CCB</sub> are provided in the recommended operating conditions table.

### ESD Ratings

		VALUE	UNIT	
V <sub>(ESD)</sub>	Electrostatic discharge	Human-body model (HBM)	±5000	V
		Machine Model (MM)	±400	V



## PACKAGE/ORDERING INFORMATION

PRODUCT	ORDERING NUMBER	TEMPERATURE RANGE	PACKAGE LEAD	PACKAGE MARKING <sup>(1)</sup>	MSL <sup>(2)</sup>	PACKAGE OPTION
RS0101	RS0101YH6	-40°C ~+85°C	SOT23-6	0101	MSL3	Tape and Reel,3000
	RS0101YC6	-40°C ~+85°C	SOT363(SC70-6)	0101 $\underline{X}$	MSL3	Tape and Reel,3000
	RS0101YUTDV6	-40°C ~+85°C	DFN1.45x1.0-6L	101	MSL3	Tape and Reel,3000

NOTE:

- (1) There may be additional marking, which relates to the lot trace code information(data code and vendor code), the logo or the environmental category on the device.
- (2) MSL, The Moisture Sensitivity Level rating according to the JEDEC industry standard classifications.

## Recommended Operating Conditions

$V_{CCI}$  is the supply voltage associated with the input port.  $V_{CCO}$  is the supply voltage associated with the output port.

PARAMETER	CONDITIONS		MIN	TYP	MAX	UNIT
Supply voltage <sup>(1)</sup>	$V_{CCA}$		1.65		5.5	V
	$V_{CCB}$		2.3		5.5	
High-level input voltage ( $V_{IH}$ )	A-port I/Os	$V_{CCA} = 1.65\text{ V to }1.95\text{ V}$ $V_{CCB} = 2.3\text{ V to }5.5\text{ V}$	$V_{CCI} - 0.2$		$V_{CCI}$	V
		$V_{CCA} = 1.65\text{ V to }3.6\text{ V}$ $V_{CCB} = 2.3\text{ V to }5.5\text{ V}$	$V_{CCI} - 0.4$		$V_{CCI}$	V
	B-port I/Os	$V_{CCA} = 1.65\text{ V to }3.6\text{ V}$ $V_{CCB} = 2.3\text{ V to }5.5\text{ V}$	$V_{CCI} - 0.4$		$V_{CCI}$	V
	OE input	$V_{CCA} = 1.65\text{ V to }3.6\text{ V}$ $V_{CCB} = 2.3\text{ V to }5.5\text{ V}$	$V_{CCA} \times 0.8$		5.5	V
Low-level input voltage ( $V_{IL}$ )	A-port I/Os	$V_{CCA} = 1.65\text{ V to }3.6\text{ V}$ $V_{CCB} = 2.3\text{ V to }5.5\text{ V}$	0		0.15	V
	B-port I/Os	$V_{CCA} = 1.65\text{ V to }3.6\text{ V}$ $V_{CCB} = 2.3\text{ V to }5.5\text{ V}$	0		0.15	V
	OE input	$V_{CCA} = 1.65\text{ V to }3.6\text{ V}$ $V_{CCB} = 2.3\text{ V to }5.5\text{ V}$	0		$V_{CCA} \times 0.25$	V
Input transition rise or fall rate( $\Delta t/\Delta v$ )	A-port I/Os push-pull driving				10	ns/V
	B-port I/Os push-pull driving				10	ns/V
	Control input				10	ns/V
$T_A$ Operating free-air temperature			-40		85	°C

(1)  $V_{CCA}$  must be less than or equal to  $V_{CCB}$ .

(2) The maximum  $V_{IL}$  value is provided to ensure that a valid  $V_{OL}$  is maintained. The  $V_{OL}$  value is  $V_{IL}$  plus the voltage drop across the pass gate transistor.



## Electrical Characteristics

over recommended operating free-air temperature range (unless otherwise noted) <sup>(1)</sup> <sup>(2)</sup> <sup>(3)</sup>

PARAMETER	CONDITIONS	V <sub>CCA</sub>	V <sub>CCB</sub>	TEMP	MIN	TYP	MAX	UNITS
V <sub>OHA</sub>	Port A output high voltage	I <sub>OH</sub> = -20 μA V <sub>IB</sub> ≥ V <sub>CCB</sub> - 0.4V	1.65V to 5.5V	2.3V to 5.5V	Full	V <sub>CCA</sub> × 0.7	5.5	V
V <sub>OLA</sub>	Port A output low voltage	I <sub>OL</sub> = 1mA V <sub>IB</sub> ≤ 0.15 V	1.65V to 5.5V	2.3V to 5.5V	Full		0.3	
V <sub>OHB</sub>	Port B output high voltage	I <sub>OH</sub> = -20 μA V <sub>IA</sub> ≥ V <sub>CCA</sub> - 0.4 V	1.65V to 5.5V	2.3V to 5.5V	Full	V <sub>CCB</sub> × 0.7		
V <sub>OLB</sub>	Port B output low voltage	I <sub>OL</sub> = 1mA V <sub>IA</sub> ≤ 0.15 V	1.65V to 5.5V	2.3V to 5.5V	Full		0.3	
I <sub>I</sub>	Input leakage current	OE	1.65V to 5.5V	2.3V to 5.5V	+25°C		±0.5	μA
					Full		±1.5	
I <sub>off</sub>	Partial power down current	A Ports	0V	0V to 5.5V	+25°C		±0.5	μA
					Full		±1	
		B Ports	0V to 5.5V	0V	+25°C		±0.5	μA
					Full		±1	
I <sub>OZ</sub>	High-impedance State output current	A or B port OE=0V	1.65V to 5.5V	2.3V to 5.5V	+25°C		±0.5	μA
					Full		±1	
I <sub>CCA</sub>	V <sub>CCA</sub> supply current	V <sub>I</sub> = V <sub>O</sub> = open I <sub>O</sub> = 0	1.65V to V <sub>CCB</sub>	2.3V to 5.5V	Full		2.5	μA
			5.5V	0V	Full		2.5	
			0V	5.5V	Full		-1	
I <sub>CCB</sub>	V <sub>CCB</sub> supply current	V <sub>I</sub> = V <sub>O</sub> = open I <sub>O</sub> = 0	1.65V to V <sub>CCB</sub>	2.3V to 5.5V	Full		10	μA
			5.5V	0V	Full		-1	
			0V	5.5V	Full		1	
I <sub>CCA</sub> + I <sub>CCB</sub>	Combined supply current	V <sub>I</sub> = V <sub>CC1</sub> or GND I <sub>O</sub> = 0	1.65V to V <sub>CCB</sub>	2.3V to 5.5V	Full		11	μA
I <sub>CCZA</sub>	V <sub>CCA</sub> supply current	V <sub>I</sub> = V <sub>CC1</sub> or 0V I <sub>O</sub> = 0, OE=0V	1.65V to V <sub>CCB</sub>	2.3V to 5.5V	Full		1	μA
I <sub>CCZB</sub>	V <sub>CCB</sub> supply current	V <sub>I</sub> = V <sub>CC1</sub> or 0V I <sub>O</sub> = 0, OE=0V	2.3V to 5.5V	2.3V to 5.5V	Full		1	μA
C <sub>I</sub>	Input capacitance	OE	3.3V	3.3V	+25°C		2.5	pF
C <sub>IO</sub>	Input-to-output internal capacitance	A port	3.3V	3.3V	+25°C		5	pF
		B port	3.3V	3.3V	+25°C		5	

(1) V<sub>CC1</sub> is the V<sub>CC</sub> associated with the input port.

(2) V<sub>CC0</sub> is the V<sub>CC</sub> associated with the output port

(3) V<sub>CCA</sub> must be less than or equal to V<sub>CCB</sub>.



## Timing Requirements

### $V_{CCA}=1.8V\pm 0.15V$

		$V_{CCB}=2.5V \pm 0.2V$	$V_{CCB}=3.3V \pm 0.2V$	$V_{CCB}=5V \pm 0.2V$	UNIT
		TYP	TYP	TYP	
Data rate	Push-pull driving	21	22	24	Mbps
	Open-drain driving	2	2	2	
Pulse duration( $t_w$ )	Push-pull driving (data inputs)	47	45	41	ns
	Open-drain driving (data inputs)	500	500	500	

### $V_{CCA}=2.5V\pm 0.15V$

		$V_{CCB}=2.5V \pm 0.2V$	$V_{CCB}=3.3V \pm 0.2V$	$V_{CCB}=5V \pm 0.2V$	UNIT
		TYP	TYP	TYP	
Data rate	Push-pull driving	20	22	24	Mbps
	Open-drain driving	2	2	2	
Pulse duration( $t_w$ )	Push-pull driving (data inputs)	50	45	41	ns
	Open-drain driving (data inputs)	500	500	500	

### $V_{CCA}=3.3V\pm 0.15V$

		$V_{CCB}=3.3V \pm 0.2V$	$V_{CCB}=5V \pm 0.2V$	UNIT
		TYP	TYP	
Data rate	Push-pull driving	23	24	Mbps
	Open-drain driving	2	2	
Pulse duration( $t_w$ )	Push-pull driving (data inputs)	43	41	ns
	Open-drain driving (data inputs)	500	500	

### $V_{CCA}=5V\pm 0.15V$

		$V_{CCB}=5V \pm 0.2V$	UNIT
		TYP	
Data rate	Push-pull driving	24	Mbps
	Open-drain driving	2	
Pulse duration( $t_w$ )	Push-pull driving (data inputs)	41	ns
	Open-drain driving (data inputs)	500	





### Switching Characteristics: $V_{CCA}=1.8V \pm 0.15V$

over recommended operating free-air temperature range (unless otherwise noted)

PARAMETER	CONDITIONS		$V_{CCB}=2.5V \pm 0.2V$	$V_{CCB}=3.3V \pm 0.2V$	$V_{CCB}=5V \pm 0.2V$	UNITS
			TYP	TYP	TYP	
$t_{PHL}$ Propagation delay time high-to-low output	A-to-B	Push-pull driving	2.5	3.1	4.5	ns
		Open-drain driving	26.1	26.4	26.6	
$t_{PLH}$ Propagation delay time low-to-high output	A-to-B	Push-pull driving	4.2	3.7	3.6	ns
		Open-drain driving	221	183	143	
$t_{PHL}$ Propagation delay time high-to-low output	B-to-A	Push-pull driving	2.1	2.0	2.2	ns
		Open-drain driving	26.1	26.1	26.2	
$t_{PLH}$ Propagation delay time low-to-high output	B-to-A	Push-pull driving	1.8	1.6	1.5	ns
		Open-drain driving	173	89	66	
$t_{en}$ Enable time	OE-to-A or B		25	21	19	ns
$t_{dis}$ Disable time	OE-to-A or B		1250	1250	1250	ns
$t_{rA}$ Input rise time	A port rise time	Push-pull driving	6.9	6.1	5.6	ns
		Open-drain driving	118	39	13	
$t_{rB}$ Input rise time	B port rise time	Push-pull driving	5.8	4.8	4.1	ns
		Open-drain driving	166	127	75	
$t_{fA}$ Input fall time	A port fall time	Push-pull driving	3.0	2.8	2.7	ns
		Open-drain driving	1.9	1.7	1.6	
$t_{fB}$ Input fall time	B port fall time	Push-pull driving	4.8	6.2	8.4	ns
		Open-drain driving	2.3	2.4	2.8	
$t_{sk(O)}$ Skew(time), output	Channel-to-Channel Skew		0.5	0.5	0.5	ns
Maximum data rata	Push-pull driving		21	22	24	Mbps
	Open-drain driving		2	2	2	



### Switching Characteristics: $V_{CCA}=2.5V \pm 0.15V$

over recommended operating free-air temperature range (unless otherwise noted)

PARAMETER	CONDITIONS		$V_{CCB}=2.5V \pm 0.2V$	$V_{CCB}=3.3V \pm 0.2V$	$V_{CCB}=5V \pm 0.2V$	UNITS
			TYP	TYP	TYP	
$t_{PHL}$ Propagation delay time high-to-low output	A-to-B	Push-pull driving	2.8	3.4	5.0	ns
		Open-drain driving	26.3	26.5	26.6	
$t_{PLH}$ Propagation delay time low-to-high output	A-to-B	Push-pull driving	2.7	2.5	2.4	ns
		Open-drain driving	198	169	131	
$t_{PHL}$ Propagation delay time high-to-low output	B-to-A	Push-pull driving	2.5	2.4	2.5	ns
		Open-drain driving	26.4	26.5	26.6	
$t_{PLH}$ Propagation delay time low-to-high output	B-to-A	Push-pull driving	2.1	2.0	1.9	ns
		Open-drain driving	196	138	63	
$t_{en}$ Enable time	OE-to-A or B		24	20	17	ns
$t_{dis}$ Disable time	OE-to-A or B		1250	1250	1250	ns
$t_{rA}$ Input rise time	A port rise time	Push-pull driving	3.4	2.9	2.7	ns
		Open-drain driving	156	92	13	
$t_{rB}$ Input rise time	B port rise time	Push-pull driving	4.7	3.5	2.7	ns
		Open-drain driving	160	124	81	
$t_{fA}$ Input fall time	A port fall time	Push-pull driving	5.1	5.2	5.0	ns
		Open-drain driving	2.1	2.0	1.8	
$t_{fB}$ Input fall time	B port fall time	Push-pull driving	5.0	6.4	8.7	ns
		Open-drain driving	2.0	2.2	2.8	
$t_{SK(O)}$ Skew(time), output	Channel-to-channel skew		0.5	0.5	0.5	ns
Maximum data rata	Push-pull driving		20	22	24	Mbps
	Open-drain driving		2	2	2	



### Switching Characteristics: $V_{CCA}=3.3V \pm 0.3V$

over recommended operating free-air temperature range (unless otherwise noted)

PARAMETER	CONDITIONS		$V_{CCB}=3.3V\pm0.2V$	$V_{CCB}=5V\pm0.2V$	UNITS
			TYP	TYP	
$t_{PHL}$ Propagation delay time high-to-low output	A-to-B	Push-pull driving	3.6	5.1	ns
		Open-drain driving	26.4	26.6	
$t_{PLH}$ Propagation delay time low-to-high output	A-to-B	Push-pull driving	2.3	2.1	ns
		Open-drain driving	155	109	
$t_{PHL}$ Propagation delay time high-to-low output	B-to-A	Push-pull driving	3.1	3.3	ns
		Open-drain driving	26.5	26.7	
$t_{PLH}$ Propagation delay time low-to-high output	B-to-A	Push-pull driving	1.9	1.8	ns
		Open-drain driving	158	87	
$t_{en}$ Enable time	OE-to-A or B		19	15	ns
$t_{dis}$ Disable time	OE-to-A or B		1250	1250	ns
$t_{rA}$ Input rise time	A port rise time	Push-pull driving	2.3	2.1	ns
		Open-drain driving	117	48	
$t_{rB}$ Input rise time	B port rise time	Push-pull driving	3.0	2.4	ns
		Open-drain driving	117	75	
$t_{fA}$ Input fall time	A port fall time	Push-pull driving	8.0	7.6	ns
		Open-drain driving	2.2	2.1	
$t_{fB}$ Input fall time	B port fall time	Push-pull driving	8.2	10.8	ns
		Open-drain driving	2.1	2.4	
$t_{SK(O)}$ Skew(time), output	Channel-to-channel skew		0.5	0.5	ns
Maximum data rata	Push-pull driving		23	24	Mbps
	Open-drain driving		2	2	



### Switching Characteristics: $V_{CCA}=5.0V \pm 0.35V$

over recommended operating free-air temperature range (unless otherwise noted)

PARAMETER	CONDITIONS		$V_{CCB}=5V \pm 0.2V$	UNITS
			TYP	
$t_{PHL}$ Propagation delay time high-to-low output	A-to-B	Push-pull driving	5.6	ns
		Open-drain driving	26.8	
$t_{PLH}$ Propagation delay time low-to-high output	A-to-B	Push-pull driving	2.0	ns
		Open-drain driving	155	
$t_{PHL}$ Propagation delay time high-to-low output	B-to-A	Push-pull driving	5.8	ns
		Open-drain driving	27.5	
$t_{PLH}$ Propagation delay time low-to-high output	B-to-A	Push-pull driving	1.8	ns
		Open-drain driving	160	
$t_{en}$ Enable time	OE-to-A or B		17	ns
$t_{dis}$ Disable time	OE-to-A or B		1250	ns
$t_{rA}$ Input rise time	A port rise time	Push-pull driving	1.9	ns
		Open-drain driving	105	
$t_{rB}$ Input rise time	B port rise time	Push-pull driving	2.3	ns
		Open-drain driving	95	
$t_{fA}$ Input fall time	A port fall time	Push-pull driving	9.0	ns
		Open-drain driving	2.6	
$t_{fB}$ Input fall time	B port fall time	Push-pull driving	8.9	ns
		Open-drain driving	2.5	
$t_{SK(O)}$ Skew(time), output	Channel-to-channel skew		0.5	ns
Maximum data rata	Push-pull driving		24	Mbps
	Open-drain driving		2	

## Parameter Measurement Information

Unless otherwise noted, all input pulses are supplied by generators having the following characteristics:

- PRR 10 MHz
- $Z_o = 50 \Omega$
- $dv/dt \geq 1 \text{ V/ns}$

Note: All input pulses are measured one at a time, with one transition per measurement.

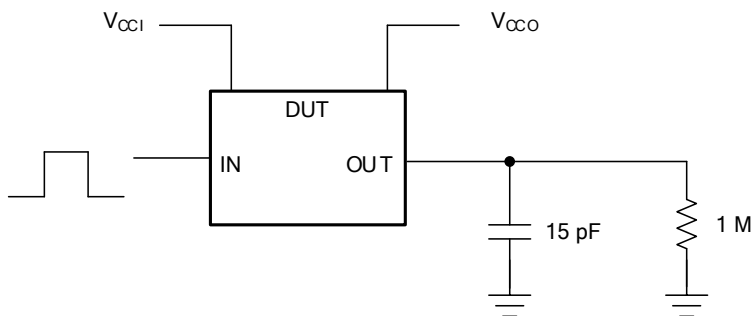

Figure 1. Data Rate, Pulse Duration, Propagation Delay, Output Rise And Fall Time Measurement Using A Push-Pull Driver

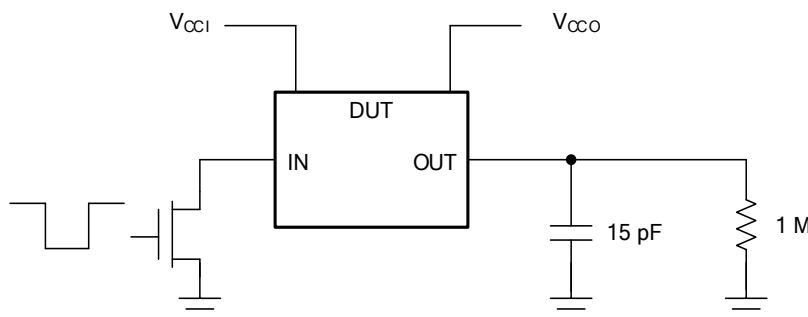

Figure 2. Data Rate, Pulse Duration, Propagation Delay, Output Rise And Fall Time Measurement Using An Open-Drain Driver

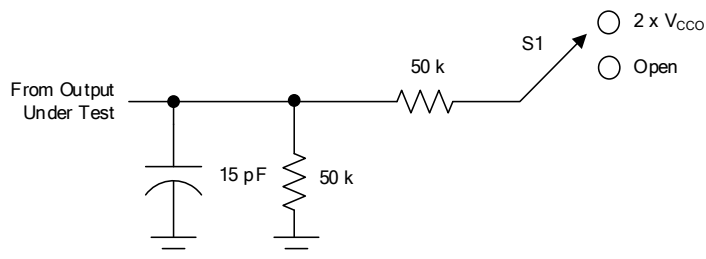

Figure 3. Load Circuit For Enable/Disable Time Measurement

Table 1. Switch Configuration For Enable/Disable Timing

TEST	S1
$t_{PZL}^{(1)}$ , $t_{PLZ}^{(2)}$	$2 \times V_{CC0}$
$t_{PHZL}^{(1)}$ , $t_{PHZ}^{(2)}$	Open

(1)  $t_{PZL}$  and  $t_{PHZ}$  are the same as  $t_{en}$ .

(2)  $t_{PLZ}$  and  $t_{PHZ}$  are the same as  $t_{dis}$ .

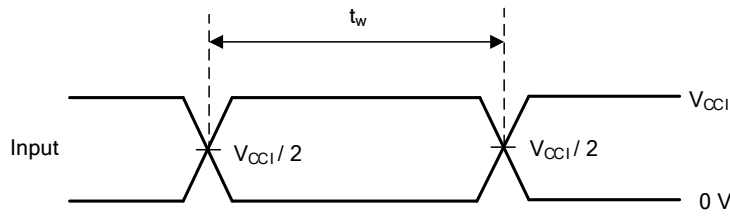

(1) All input pulses are measured one at a time, with one transition per measurement.

Figure 4. Voltage Waveforms Pulse Duration

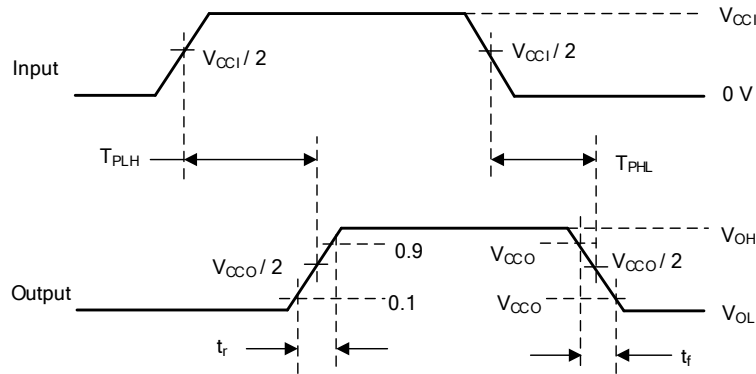

Figure 5. Voltage Waveforms Propagation Delay Times

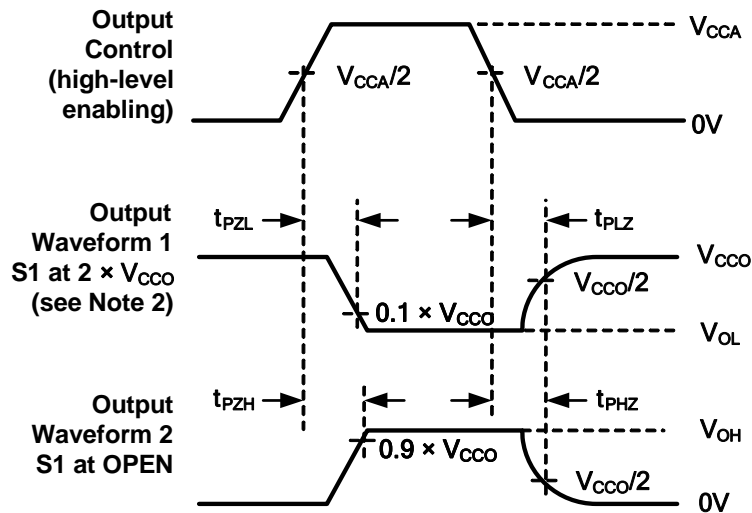

Figure 6. Voltage Waveforms Enable And Disable

## Feature Description

### Overview

The RS0101 device is a directionless voltage-level translator specifically designed for translating logic voltage levels. The A port is able to accept I/O voltages ranging from 1.65 V to 5.5 V, while the B port can accept I/O voltages from 2.3 V to 5.5 V. The device is a pass-gate architecture with edge-rate accelerators (one-shots) to improve the overall data rate. 10-k $\Omega$  pullup resistors, commonly used in open-drain applications, have been conveniently integrated so that an external resistor is not needed. While this device is designed for open-drain applications, the device can also translate push-pull CMOS logic outputs.

### Architecture

The RS0101 architecture (see Figure 7) is an auto-direction-sensing based translator that does not require a direction-control signal to control the direction of data flow from A to B or from B to A. These two bidirectional channels independently determine the direction of data flow without a direction-control signal. Each I/O pin can be automatically reconfigured as either an input or an output, which is how this auto-direction feature is realized.

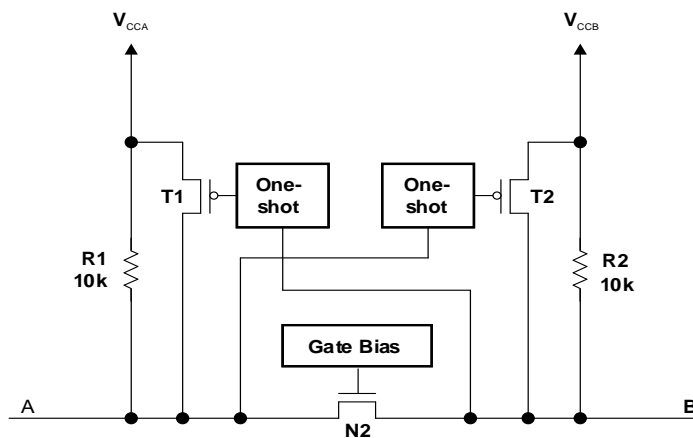

Figure 7. Architecture of a RS0101 Cell

The RS0101 employs two key circuits to enable this voltage translation:

- 1) An N-channel pass-gate transistor topology that ties the A-port to the B-port
- 2) Output one-shot (O.S.) edge-rate accelerator circuitry to detect and accelerate rising edges on the A or B Ports.

### Input Driver Requirements

The continuous dc-current "sinking" capability is determined by the external system-level open-drain (or push-pull) drivers that are interfaced to the RS0101 I/O pins. Since the high bandwidth of these bidirectional I/O circuits is used to facilitate this fast change from an input to an output and an output to an input, they have a modest dc-current "sourcing" capability of hundreds of micro-Amps, as determined by the internal 10-k $\Omega$  pullup resistors.

The fall time ( $t_{fA}$ ,  $t_{fB}$ ) of a signal depends on the edge-rate and output impedance of the external device driving RS0101 data I/Os, as well as the capacitive loading on the data lines.

Similarly, the  $t_{PHL}$  and max data rates also depend on the output impedance of the external driver. The values for  $t_{fA}$ ,  $t_{fB}$ ,  $t_{PHL}$ , and maximum data rates in the data sheet assume that the output impedance of the external driver is less than 50  $\Omega$ .

## Feature Description

### Output Load Considerations

We recommend careful PCB layout practices with short PCB trace lengths to avoid excessive capacitive loading and to ensure that proper O.S. triggering takes place. PCB signal trace-lengths should be kept short enough such that the round-trip delay of any reflection is less than the one-shot duration. This improves signal integrity by ensuring that any reflection sees a low impedance at the driver. The O.S. circuits have been designed to stay on for approximately 30 ns. The maximum capacitance of the lumped load that can be driven also depends directly on the one-shot duration. With very heavy capacitive loads, the one-shot can time-out before the signal is driven fully to the positive rail. The O.S. duration has been set to best optimize trade-offs between dynamic ICC, load driving capability, and maximum bit-rate considerations. Both PCB trace length and connectors add to the capacitance that the RS0101 device output sees, so it is recommended that this lumped-load capacitance be considered to avoid O.S. retriggering, bus contention, output signal oscillations, or other adverse system-level affects.

### Enable and Disable

The RS0101 device has an OE input that is used to disable the device by setting OE low, which places all I/Os in the Hi-Z state. The disable time ( $t_{dis}$ ) indicates the delay between the time when OE goes low and when the outputs are disabled (Hi-Z). The enable time ( $t_{en}$ ) indicates the amount of time the user must allow for the one-shot circuitry to become operational after OE is taken high.

### Pullup or Pulldown Resistors on I/O Lines

Each A-port I/O has an internal 10-k $\Omega$  pullup resistor to  $V_{CCA}$ , and each B-port I/O has an internal 10-k $\Omega$  pullup resistor to  $V_{CCB}$ . If a smaller value of pullup resistor is required, an external resistor must be added from the I/O to  $V_{CCA}$  or  $V_{CCB}$  (in parallel with the internal 10-k $\Omega$  resistors). Adding lower value pull-up resistors will affect  $V_{OL}$  levels, however. The internal pull-ups of the RS0101 are disabled when the OE pin is low.



## Application Information

The RS0101 device can be used to bridge the digital-switching compatibility gap between two voltage nodes to successfully interface logic threshold levels found in electronic systems. It should be used in a point-to-point topology for interfacing devices or systems operating at different interface voltages with one another. Its primary target application use is for interfacing with open-drain drivers on the data I/Os such as I<sup>2</sup>C or 1-wire, where the data is bidirectional and no control signal is available. The device can also be used in applications where a push-pull driver is connected to the data I/Os, but the RS0101 might be a better option for such push-pull applications.

### Typical Application

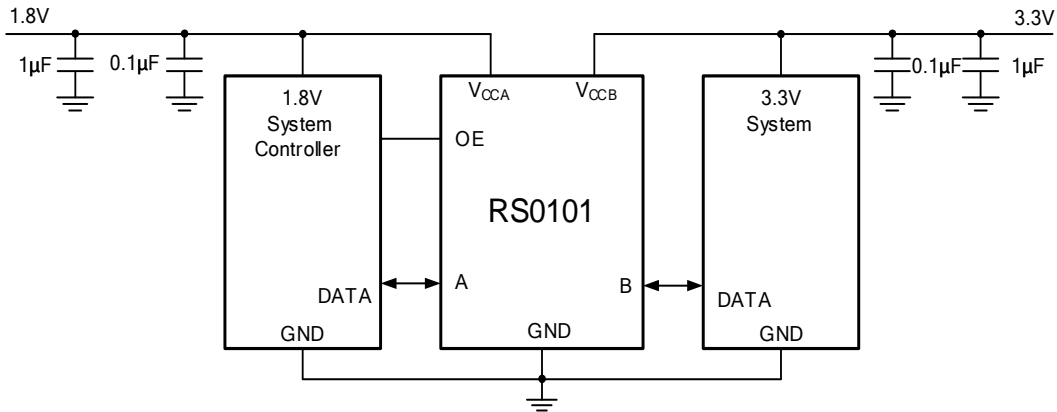
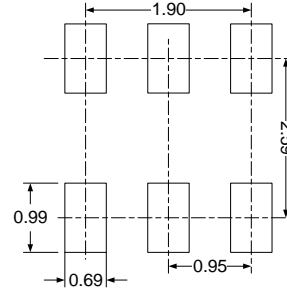
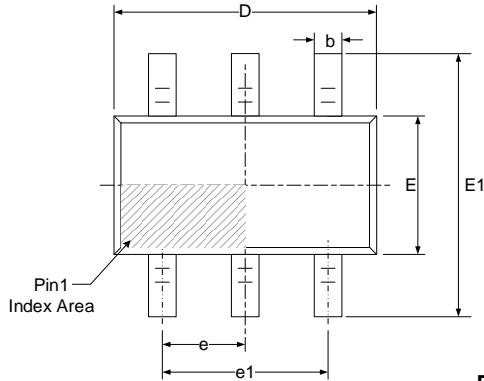
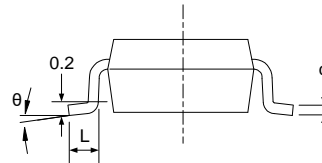
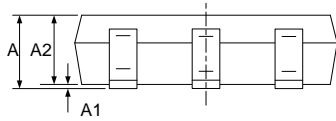

Figure 8. Typical Application Circuit

## PACKAGE OUTLINE DIMENSIONS SOT23-6



RECOMMENDED LAND PATTERN (Unit: mm)



Symbol	Dimensions In Millimeters		Dimensions In Inches	
	Min	Max	Min	Max
A	1.050	1.250	0.041	0.049
A1	0.000	0.100	0.000	0.004
A2	1.050	1.150	0.041	0.045
b	0.300	0.500	0.012	0.020
c	0.100	0.200	0.004	0.008
D	2.820	3.020	0.111	0.119
E	1.500	1.700	0.059	0.067
E1	2.650	2.950	0.104	0.116
e	0.950(BSC)		0.037(BSC)	
e1	1.800	2.000	0.071	0.079
L	0.300	0.600	0.012	0.024
$\theta$	0°	8°	0°	8°

# SOT363 (SC70-6)

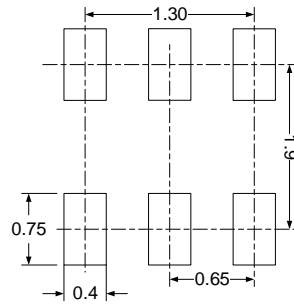
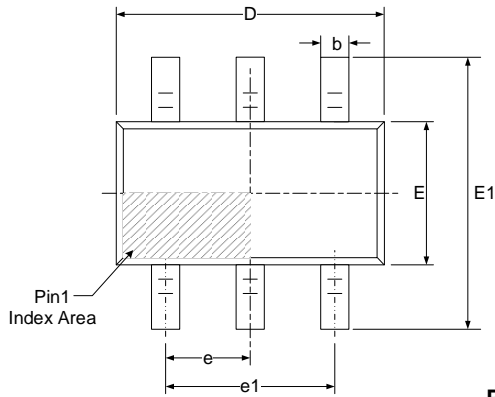

RECOMMENDED LAND PATTERN (Unit: mm)

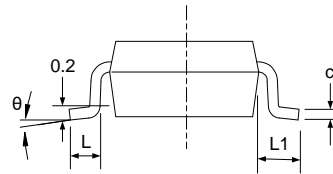
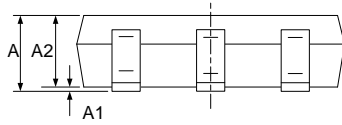

Symbol	Dimensions In Millimeters		Dimensions In Inches	
	Min	Max	Min	Max
A	0.900	1.100	0.035	0.043
A1	0.000	0.100	0.000	0.004
A2	0.900	1.000	0.035	0.039
b	0.150	0.350	0.006	0.014
c	0.080	0.150	0.003	0.006
D	2.000	2.200	0.079	0.087
E	1.150	1.350	0.045	0.053
E1	2.150	2.450	0.085	0.096
e	0.650(BSC)		0.026(BSC)	
e1	1.300(BSC)		0.051(BSC)	
L	0.260	0.460	0.010	0.018
L1	0.525		0.021	
θ	0°	8°	0°	8°

# DFN1.45x1.0-6L

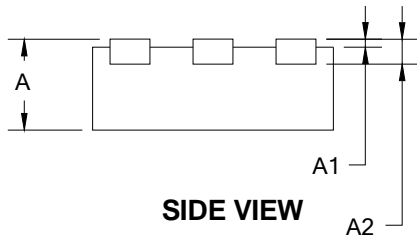
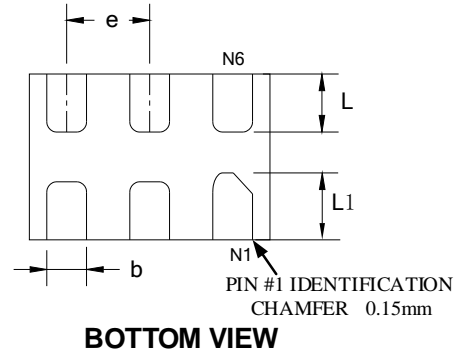
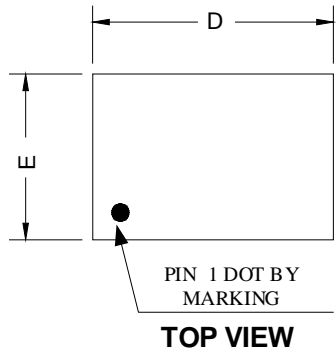

Symbol	Dimensions In Millimeters		Dimensions In Inches	
	Min	Max	Min	Max
A	0.500	0.600	0.020	0.024
A1	0.000	0.050	0.000	0.002
A2	0.150 REF		0.006 REF	
D	1.400	1.500	0.055	0.059
E	0.950	1.050	0.037	0.041
b	0.180	0.280	0.007	0.011
e	0.500 BSC		0.020 BSC	
L	0.250	0.450	0.010	0.018
L1	0.300	0.500	0.012	0.020