



ALLYSTAR

Multi-Band Multi-System GNSS Positioning Module

TAU1302

Datasheet V1.3

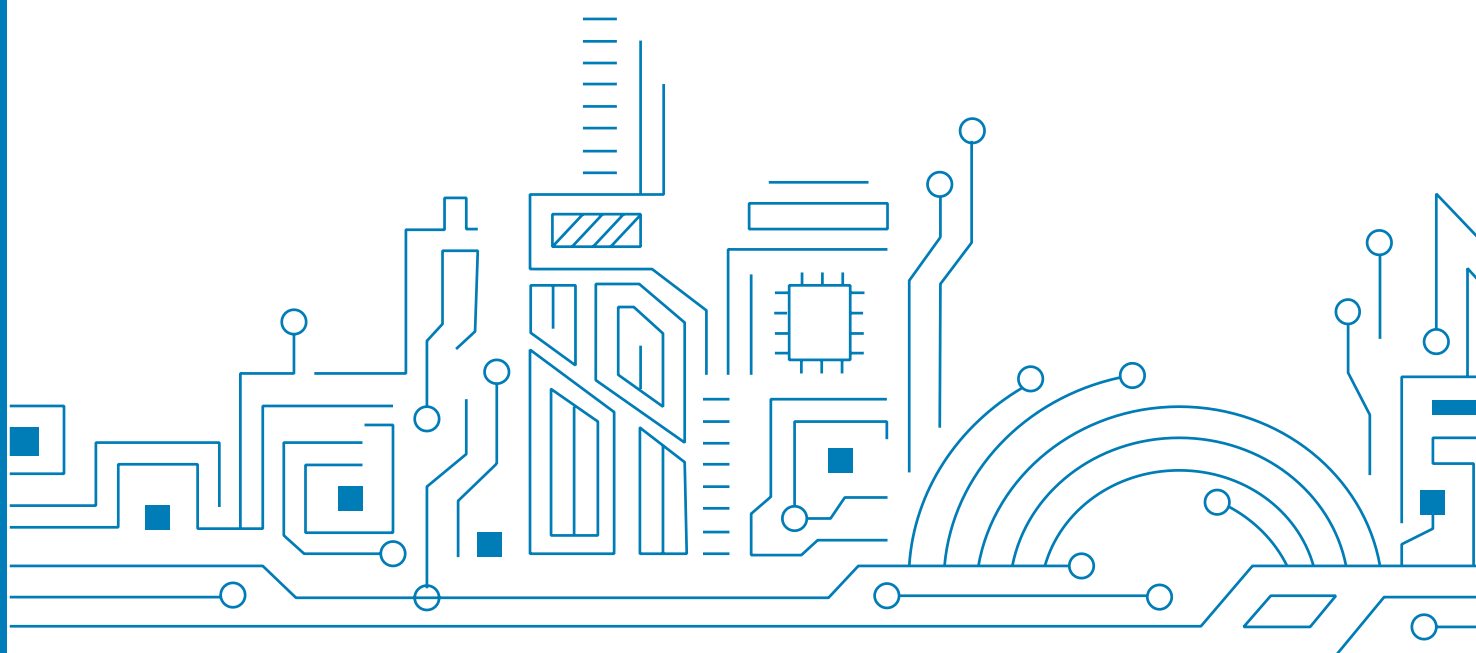

Notice, Statement and Copyright

ALLYSTAR Technology offers this document as a service to its customers, to support application and engineering efforts that use the products designed by ALLYSTAR Technology. Products and specifications discussed herein are for reference purposes only. Performance characteristics listed in this document do not constitute a warranty or guarantee of product performance.

ALLYSTAR Technology assumes no liability or responsibility for any claims or damages arising out of the use of this document, or from the use of integrated circuits based on this document, including, but not limited to claims or damages based on infringement of patents, copyrights or other intellectual property rights.

This document contains proprietary technical information which is the property of ALLYSTAR Technology, copying of this document and giving it to others and using or communication of the contents thereof, are forbidden without express authority. Offenders are liable to the payment of damages. ALLYSTAR Technology reserves the right to make changes in its products, specifications and other information at any time without notice.

For more recent documents, please visit www.allystar.com.

Copyright © Allystar Technology (Shenzhen) Co., Ltd. 2020. All rights reserved.

TABLE OF CONTENT

1	SYSTEM OVERVIEW	5
	1.1 Overview	5
	1.2 Features.....	5
	1.3 Module photo	5
	1.4 Block diagram.....	6
	1.5 Specifications	6
	1.6 GNSS Reception.....	7
2	PIN DESCRIPTION.....	8
	2.1 Pin assignment	8
	2.2 Detailed pin descriptions	9
3	ELECTRICAL CHARACTERISTICS	10
	3.1 Absolute Maximum Rating.....	10
	3.2 IO Characteristics	10
	3.2.1 PRRSTX and PRTRG	10
	3.2.2 USB I/O	10
	3.2.3 Others.....	11
	3.3 DC Characteristics	11
	3.3.1 Operating Conditions	11
	3.3.2 Power Consumption.....	11
4	HARDWARE DESCRIPTION	12
	4.1 Connecting power	12
	4.2 Antenna design	12
	4.3 Reset and mode control	12
	4.4 Serial interfaces.....	13
5	MECHANICAL SPECIFICATION	14
6	REFERENCE DESIGN.....	15
	6.1 Minimal design.....	15
	6.2 PCB Footprint Reference	16
	6.3 Layout Notes	16
7	PRODUCT PACKAGING AND HANDLING	17
	7.1 Packaging.....	17
	7.1.1 Packaging Notes	17
	7.1.2 Tape and Reel	17
	7.1.3 Shipment Packaging	18
	7.2 Storage	19

7.3	ESD Handling	19
7.3.1	ESD Handling Precautions	19
7.3.2	ESD protection measures	19
7.3.3	Moisture sensitivity level	19

8 REVISION HISTORY 20

List of tables

Table 1	Specifications	6
Table 2	GNSS reception table	7
Table 3	Detailed pin descriptions	9
Table 4	Absolute rating	10
Table 5	PRRSTX and PRTRG	10
Table 6	USB signal	10
Table 7	Others	11
Table 8	Operating conditions	11
Table 9	Power consumption	11
Table 10	Dimensions	14
Table 11	Packing hierarchy	17

List of figures

Figure 1	TAU1302 module photo	5
Figure 2	Block diagram	6
Figure 3	Pin assignment (top view)	8
Figure 4	Dimensions	14
Figure 5	Minimal application diagram	15
Figure 6	PCB Footprint Reference	16
Figure 7	Tape dimensions	17
Figure 8	Reel dimensions	18
Figure 9	Packaging	18

1 SYSTEM OVERVIEW

1.1 Overview

TAU1302 is a high-performance dual-band GNSS positioning module, which is based on the state of the art CYNOSURE III architecture. It supports BDS-3 (BeiDou Navigation Satellite System 3). Besides, it is capable of tracking all the global civil navigation systems (BDS, GPS, GLONASS, Galileo, QZSS, IRNSS, and SBAS). TAU1302 integrates efficient power management architecture, while providing high precision, high sensitivity and low power GNSS solutions which make it suitable for high precision industries, like precision agriculture, surveying and mapping, deformation monitoring, UAV (Unmanned Aerial Vehicle), etc.

1.2 Features

- Compact size for high precision industry
- Concurrent reception of multi-band multi-system GNSS signals by three RF settings:
 - Option A: L1 & L5
 - Option B: L1 & L2
 - Option C: L1 & L6
- State-of-art low power consumption
- Supports multi-band multi-system high-precision raw data output, easy for 3rd party integration
- Highly integrated module, the best cost-effective high precision GNSS solution

1.3 Module photo



Figure 1 TAU1302 module photo

1.4 Block diagram

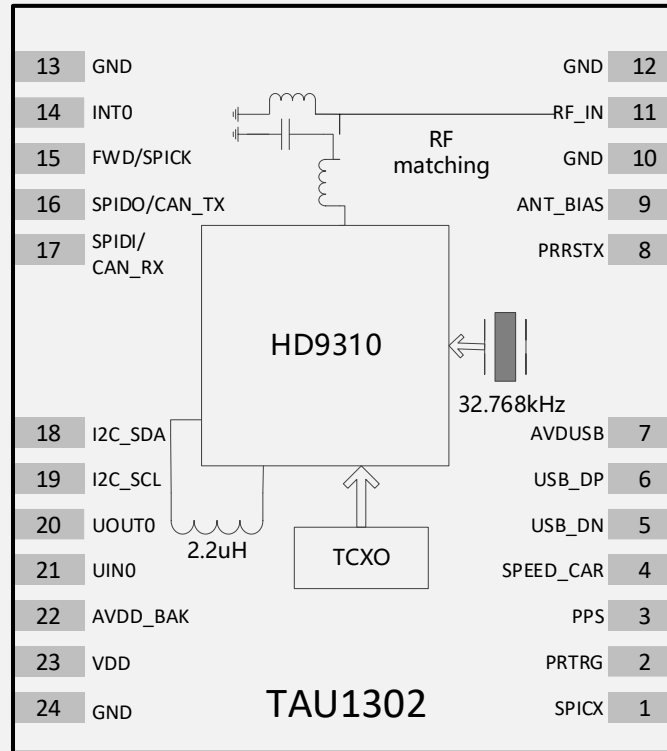

Figure 2 Block diagram

1.5 Specifications

Table 1 Specifications

Parameter	Specification	
GNSS Tracking channel	40 channels	
GNSS Reception	GPS/QZSS: L1C/A, L1C, L2C, L5, L6	
	BDS: B1I, B1C, B2I, B2a, B3I	
	GLONASS: L1OF, L2OF	
	Galileo: E1, E5a, E6	
	SBAS: L1	
Update rate	Maximum 10Hz	
Position accuracy ^[1]	GNSS	<1m CEP
Velocity & Time accuracy	GNSS	0.1m/s CEP
	1PPS	20ns
Time to First Fix(TTFF)	Hot start	1 sec
	Cold start	24 secs
Sensitivity	Cold start	-148dBm
	Hot start	-158dBm
	Reacquisition	-160dBm
	Tracking & navigation	-162dBm

Parameter	Specification	
Operating limit	Velocity	515m/s
	Altitude	18,000m
Safety supervision	Antenna short circuit protection and open circuit detection	
	System clock stop detection	
	Low voltage detection	
Serial interface	USB	1
	SPI	1
	UART	1
	I2C	1
	CAN ^[2]	1
Protocol	NMEA 0183 Protocol Ver. 4.00/4.10, Cynosure GNSS Receiver Protocol	
Operating condition	Main voltage	1.8 ~ 3.6V
	Digital I/O voltage	1.8 ~ 3.6V
	Backup voltage	1.8 ~ 3.6V
Power consumption	GPS+QZSS, L1 band	22mA ^[3] @3.3V
	GNSS, L1+L5 band	34mA ^[4] @3.3V
	GNSS, L1+L2 band	34mA ^[5] @3.3V
	GNSS, L1+L6 band	34mA ^[6] @3.3V
	Standby	12uA ^[7]
Operating temperature	-40 °C ~ +85 °C	
Storage temperature	-40 °C ~ +85 °C	
Package	12.2mm x 16.0mm x 2.4mm 24-pin stamp hole	
Certification	RoHS & REACH	

* [1] Demonstrated with a good external LNA

* [2] Only customized firmware supported

* [3] Open sky conditions, GPS+QZSS, L1 band, 16 tracked Satellites

* [4] Open sky conditions, GPS+BDS+QZSS+GLONASS+Galileo, L1+L5 band, 32 tracked Satellites

* [5] Open sky conditions, GPS+BDS+QZSS+GLONASS+Galileo, L1+L2 band, 32 tracked Satellites

* [6] Open sky conditions, GPS+BDS+QZSS+GLONASS+Galileo, L1+L6 band, 32 tracked Satellites

* [7] Standby under RTC mode, wake up by PRTRG and RTC time-out

1.6 GNSS Reception

Table 2 GNSS reception table

P/N	RF MODE	GPS/QZSS						BDS					GLONASS		Galileo			IRNSS	SBAS
		L1C/A	L1C	L2C	L5	L6	B1I	B1C	B2I	B2a	B3I	L1	L2	E1	E5	E6	L5	L1	
TAU1302	A (L1+ L5)	●	● ^[3]	-	●	-	●	● ^[3]	-	●	-	●	-	●	● ^[1]	-	● ^[3]	●	
	B (L1+ L2)	●	● ^[3]	● ^[2]	-	-	●	● ^[3]	●	-	-	●	●	●	-	-	-	●	
	C (L1+ L6)	●	● ^[3]	-	-	●	●	● ^[3]	-	-	●	●	-	●	-	●	-	●	

* [1] Supports E5a and Pilot channel only

* [2] Supports L2CM

* [3] Supported by specific firmware upgrade

2 PIN DESCRIPTION

2.1 Pin assignment

13	GND	GND	12
14	INT0	RF_IN	11
15	FWD/SPICK	GND	10
16	SPIDO/CAN_TX	ANT_BIAS	9
17	SPIDI/CAN_RX	PRRSTX	8
TAU1302			
18	I2C_SDA	AVDUSB	7
19	I2C_SCL	USB_DP	6
20	UOUT0	USB_DN	5
21	UIN0	SPEED_CAR	4
22	AVDD_BAK	PPS	3
23	VDD	PRTRG	2
24	GND	SPICX	1

Figure 3 Pin assignment (top view)

2.2 Detailed pin descriptions

Table 3 Detailed pin descriptions

Function	Symbol	No.	I/O	Description
Power	VDD	23	Power	Main voltage supply. Provide clean and stable supply.
	GND	10,12, 13,24	VSS	Assure a good GND connection to all GND pins of the module, preferably with a large ground plane.
	AVDD_BAK	22	Power	Backup power supply voltage input. Backup power is needed in order to enable warm and hot start features. If no backup power is available, connect AVDD_BAK to the main power supply or leave it floating.
	AVDUSB	7	Power	USB voltage supply. To use the USB interface, connect this pin to 3.0-3.6V.
Antenna	RF_IN	11	I	Use a controlled impedance of 50Ω for the routing from RF_IN pin to the antenna or the antenna connector.
	ANT_BIAS	9	O	RF section output voltage. The ANT_BIAS pin can be used to supply powers to an external active antenna.
UART	UOUT0	20	O	UART0 serial data output.
	UIN0	21	I	UART0 serial data input.
USB	USB_DN	5	I/O	USB I/O line. USB bidirectional communication pin. Leave it floating if not used.
	USB_DP	6	I/O	
SPI	SPICX	1	O	SPI chip select
	FWD/SPICK	15	O	SPI clock
	SPIDO/CAN_TX	16	O	SPI data or CAN data output, leave it floating if not used.
	SPIDI/CAN_RX	17	I	SPI data or CAN data input, leave it floating if not used.
I2C	I2C_SDA	18	I/O	I ² C data, leave it floating if not used.
	I2C_SCL	19	O	I ² C clock, leave it floating if not used.
System	PRTRG	2	I	Mode selection, or the trigger input in deep sleep mode to wake up the system
	PRRSTX	8	I	External reset, low active
	PPS	3	O	Time pulse output (PPS)
	SPEED_CAR	4	I	Speed pulse, leave it floating if not used, default GPIO
	INT0	14	O	External interrupt, leave it floating if not used, default GPIO

3 ELECTRICAL CHARACTERISTICS

3.1 Absolute Maximum Rating

Table 4 Absolute rating

Symbol	Parameter	Min.	Max.	Unit
VDD	Power input for the main power domain	-0.5	3.63	V
AVDD_BAK	Power input for the backup power domain	-0.5	3.63	V
AVDUSB	USB supply voltage	-0.5	3.6	V
T _{storage}	Storage temperature	-40	85	°C
T _{solder}	Solder reflow temperature	--	260	°C

3.2 IO Characteristics

3.2.1 PRRSTX and PRTRG

Table 5 PRRSTX and PRTRG

Symbol	Parameter	Condition	Min.	Typ.	Max.	Unit
I _{IZ}	Input leakage current	--	--	--	+/-1	uA
V _{IH}	Input high voltage	--	AVDD_BAK*0.7	--	AVDD_BAK	V
V _{IL}	Input low voltage	--	0	--	AVDD_BAK*0.3	V
C _i	Input capacitance	--	--	--	10	pF
R _{PU}	Pull-up resistance	--	18	--	84	kOhm

3.2.2 USB I/O

Table 6 USB signal

Symbol	Parameter	Condition	Min.	Typ.	Max.	Unit
I _{IZ}	Input leakage current	--	--	--	+/-10	uA
V _{IH}	Input high voltage	--	AVDUSB*0.9	--	AVDUSB	V
V _{IL}	Input low voltage	--	0	--	AVDUSB*0.1	V
V _{OH}	Output high voltage	I _{OH} =10 mA, AVDUSB =3.3V	2.35	--	--	V
V _{OL}	Output low voltage	I _{OL} =10 mA, AVDUSB =3.3V	--	--	0.5	V
R _{PUIDEL}	Pull-up resistance, idle state	--	0.9	--	1.575	kΩ
R _{PUACTIVE}	Pull-up resistance, active state	--	1.425	--	3.09	kΩ

3.2.3 Others

Table 7 Others

Symbol	Parameter	Condition	Min.	Typ.	Max.	Unit
I _{IZ}	Input leakage current	--	--	--	+/-1	uA
V _{IH}	Input high voltage	--	VDD*0.7	--	VDD	V
V _{IL}	Input low voltage	--	0	--	VDD*0.3	V
V _{OH}	Output high voltage	I _{OH} =11.9 mA, VDD=3.3V	2.64	--	--	V
		I _{OH} =2.8 mA, VDD=1.8V	1.53	--	--	V
V _{OL}	Output low voltage	I _{OL} =7.9 mA, VDD=3.3V	--	--	0.4	V
		I _{OL} =3.9 mA, VDD=1.8V	--	--	0.45	V
C _i	Input capacitance	--	--	--	11	pF
R _{PU}	Pull-up resistance	--	35	--	84	kOhm

3.3 DC Characteristics

3.3.1 Operating Conditions

Table 8 Operating conditions

Symbol	Parameter	Min.	Typ.	Max.	Unit
VDD	Power input for the main power domain	1.8	3.3	3.6	V
AVDD_BAK	Power input for the backup power domain	1.8	3.3	3.6	V
AVDUSB	USB power input	3.0	3.3	3.6	V
ICC _{max}	Maximum operating current @ VDD	--	--	200	mA
T _{env}	Operating temperature	-40	--	85	°C

3.3.2 Power Consumption

Table 9 Power consumption

Symbol	Parameter	Measure Pin	Typ.	Unit
I _{CCR_{X1}} ^[1]	Run Mode (GPS+QZSS, L1 only)	VDD ^[3]	22	mA
I _{CCR_{X2}} ^[2]	Run Mode (All GNSS, L1+L5)	VDD ^[3]	36	mA
I _{CCDBM}	Data backup Mode	AVDD_BAK ^[4]	12	uA

* [1] GPS+QZSS, L1 band only, 16 tracking channels, position fixed

* [2] All GNSS, L1 + L5 band, 32 tracking channels, position fixed

* [3] Condition: VDD=3.3V@Room Temperature; All Pins Open.

* [4] Condition: AVDD_BAK=3.3V@Room Temperature; All Pins Open.

4 HARDWARE DESCRIPTION

4.1 Connecting power

TAU1302 positioning module has two power supply pins: VDD and AVDD_BAK. The VDD pin provides the main supply voltage, and the AVDD_BAK pin provides the backup supply voltage. In order to ensure the positioning performance, please control the ripple of the module power supply. It is recommended to use the LDO with max output current above 100mA.

If the power for VDD pin is off, the real-time clock (RTC) and battery backed RAM (BBR) are supplied through the AVDD_BAK pin. Thus, orbit information and time can be maintained and will allow a Hot or Warm start. If no backup battery is connected, the module performs a cold start at every power up if no aiding data are sent to the module.

Note: If no backup supply is available, connect the AVDD_BAK pin to VDD or leave it floating.

4.2 Antenna design

There isn't built-in LNA and SAW in the GNSS module. It is recommended to use an active antenna with gain less than 50dB and noise figure less than 1.5dB. The module has built-in short circuit detection and open circuit detection functions, which can detect the status of normal connection, and send out antenna status prompt message in NMEA data.

- Short circuit protection
 - » The module includes internal short circuit antenna detection. Once an overcurrent is detected at the ANT_BIAS port, the module will cut off this power supply automatically to prevent permanent damages.
- Open circuit detection
 - » The module can detect an open circuit in the antenna. Users can judge it from antenna status messages.

4.3 Reset and mode control

The operation mode of GNSS module is controlled by PRRSTX (nRESET) and PRTRG(BOOT) pin.

- When system powers up or PRRSTX pin is pulled from "Low" to "High", the module will execute an external reset (If the power for AVDD_BAK is always on, this external reset will not affect the ephemeris data in the backup domain).
- Drive PRTRG pin to "Low" or connect PRTRG to GND directly (not by pull-down resistance) during system power-up or the external reset (PRRSTX from "Low" to "High"), system will enter BootROM Command Mode and wait for firmware upgrading after internal system reset finish.
- Keep PRTRG pin floating during system power-up or the external reset (PRRSTX from "Low" to "High"), and system will enter User Normal Mode after internal system reset finish.
- When connecting PRRSTX and PRTRG to any host IO, DO NOT use the pull-up or pull-down resistance. Leave PRRSTX and PRTRG pins floating while the module is in normal operation.

4.4 Serial interfaces

The module provides a TTL Universal Asynchronous Receiver / Transmitter (UART) interface. The data format is: 1 start bit, 8 data bits, 1 stop bit, no checksum, and the default baud rate is 115200bps. While the module powers on, there is NMEA data outputs. The upper computer can set the operation mode and baud rate of the module through serial interface.

When the module is applied to the specific application, users can shut off the main power in order to further reduce the power consumption. To avoid the high level in serial interface influencing the normal operation, it is highly suggested to cut off the serial port when shut off the main power. Otherwise, please set the serial port to input mode or high impedance state with pull-down resistor.

5 MECHANICAL SPECIFICATION

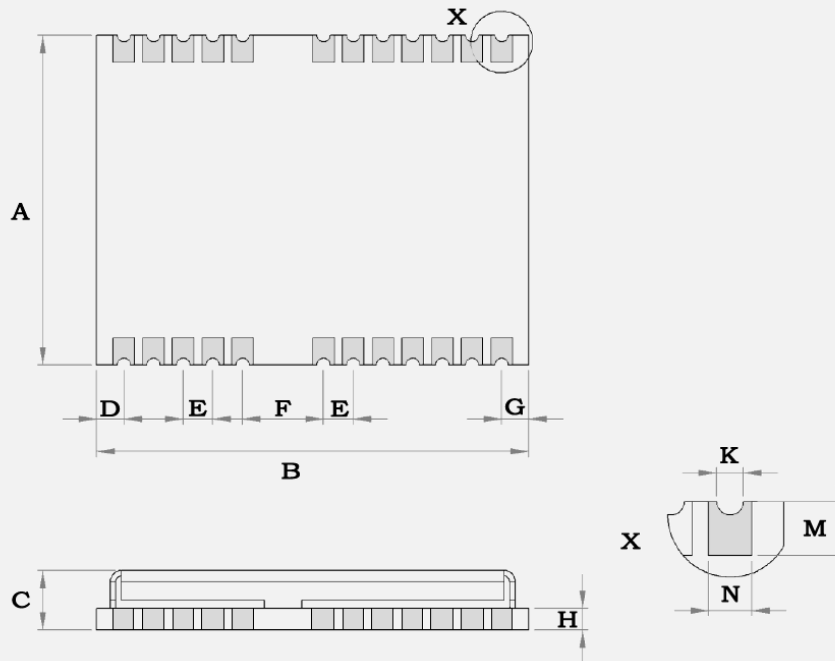

Figure 4 Dimensions

Table 10 Dimensions

Symbol	Min.(mm)	Typ.(mm)	Max.(mm)
A	12.0	12.2	12.4
B	15.8	16.0	16.2
C	2.2	2.4	2.6
D	0.9	1.0	1.3
E	1.0	1.1	1.2
F	2.9	3.0	3.1
G	0.9	1.0	1.3
H	--	0.8	--
K	0.4	0.5	0.6
M	0.8	0.9	1.0
N	0.7	0.8	0.9

6 REFERENCE DESIGN

6.1 Minimal design

This is a minimal design for a TAU1302 GNSS module. The 39nH inductor is used only when an active antenna is connected, and no need with a passive antenna. The characteristic impedance from RF_IN pin to the antenna connector should be 50Ω.

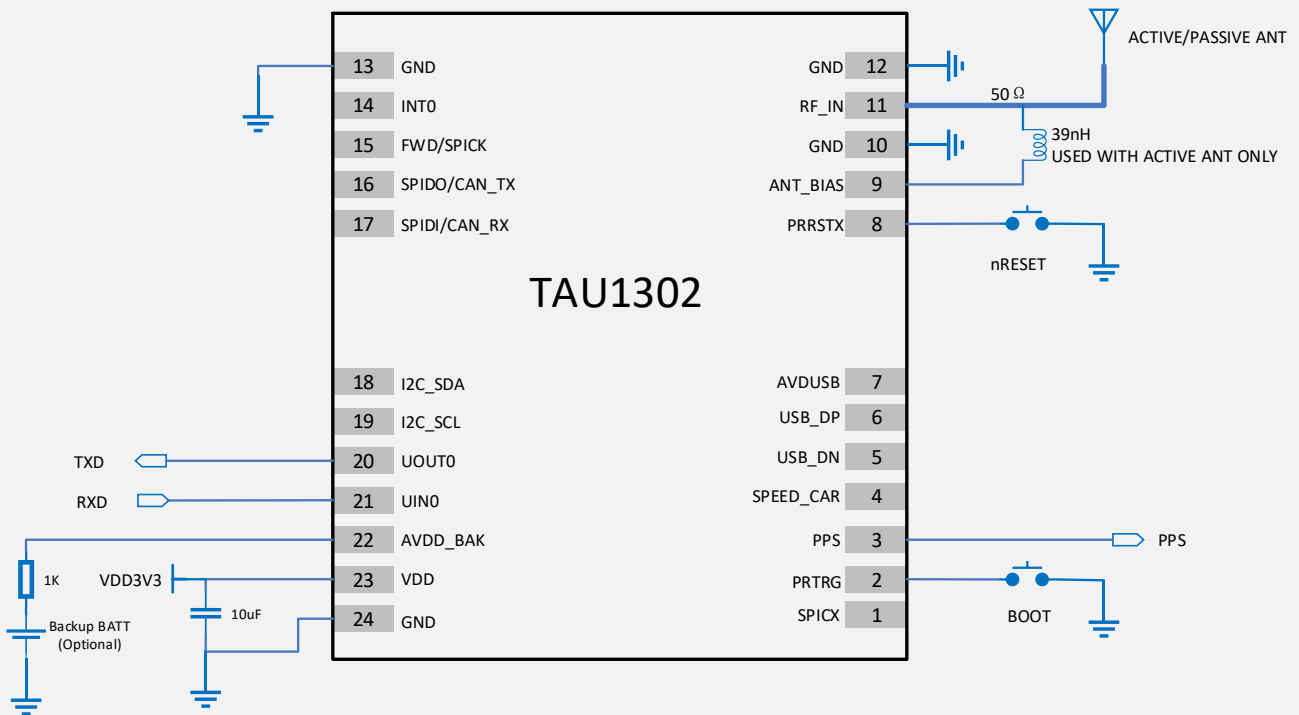

Figure 5 Minimal application diagram

6.2 PCB Footprint Reference

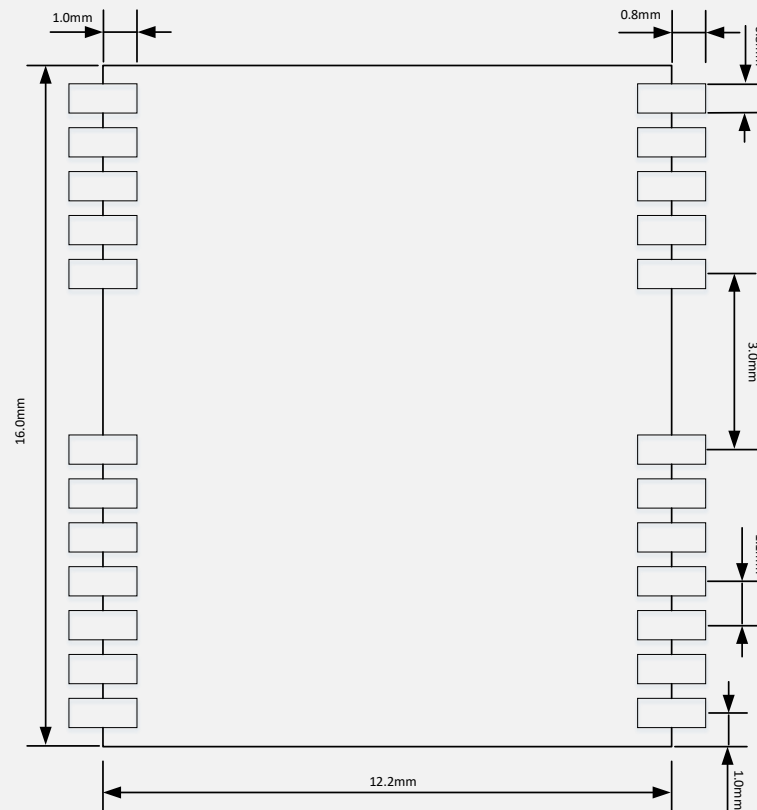

Figure 6 PCB Footprint Reference

Note: The recommended land dimensions are shown for reference only, as actual pads layouts may vary depending on application.

6.3 Layout Notes

- (1) A decoupling capacitor should be placed close to VDD pin of the module, and the width of power routing should be more than 0.5mm;
- (2) Routing under the module is not recommended.
- (3) The characteristic impedance of RF routing between RF port to antenna interface should be controlled to 50Ω.
- (4) Do not place the module close to any EMI source, like antenna, RF routing, DC/DC or power conductor, clock signal or other high-frequency switching signal, etc.





7 PRODUCT PACKAGING AND HANDLING

7.1 Packaging

7.1.1 Packaging Notes

TAU1302 is a Moisture Sensitive Device (MSD) and Electrostatic Sensitive Device (ESD). During the packing and shipping, it is strictly required to take appropriate MSD handling instructions and precautions. The table below shows the general packing hierarchy for the standard shipment.

Table 11 Packing hierarchy

Module	Reel	Sealed bag	Shipping carton
			

Note: Packaging of non-standard quantities is not explained here. Take the reality as a reference.

7.1.2 Tape and Reel

TAU1302 is delivered as hermetically sealed, reeled tapes in order to enable efficient production, production lot set-up and tear-down. The figure below shows the tape dimensions.

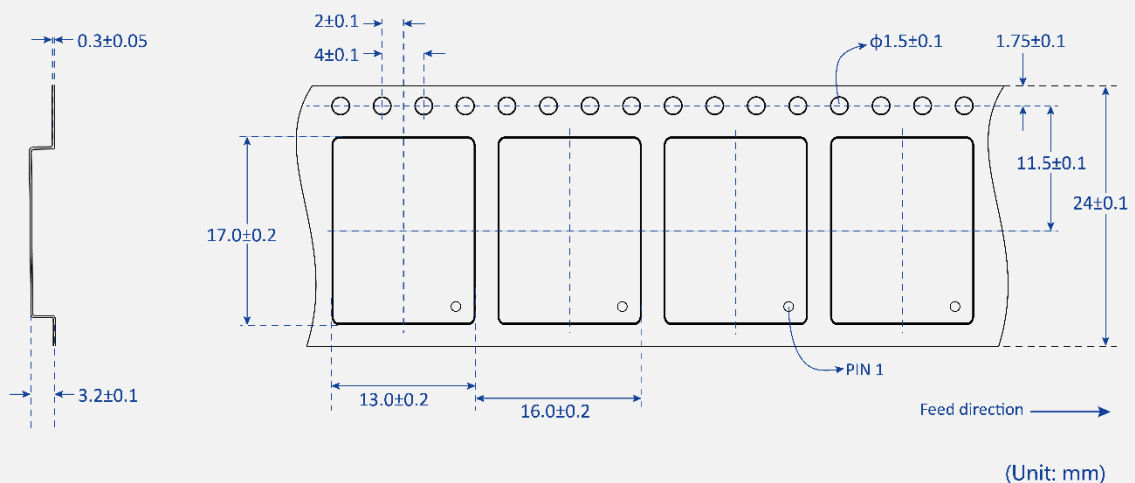
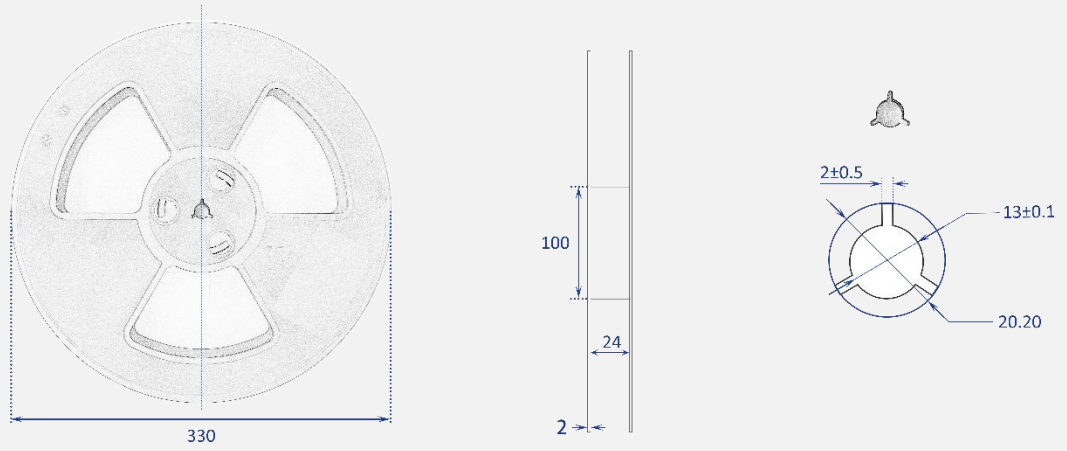

Figure 7 Tape dimensions

TAU1302 is deliverable in quantities of 1000pcs on a reel. The figure below shows the dimensions of reel for TAU1302.



(Unit: mm)

Figure 8 Reel dimensions

7.1.3 Shipment Packaging

The reels of TAU1302 are packed in the sealed bags and shipped by shipping cartons. Up to five sealed bags (5000pcs in total) can be packed in one shipping carton.

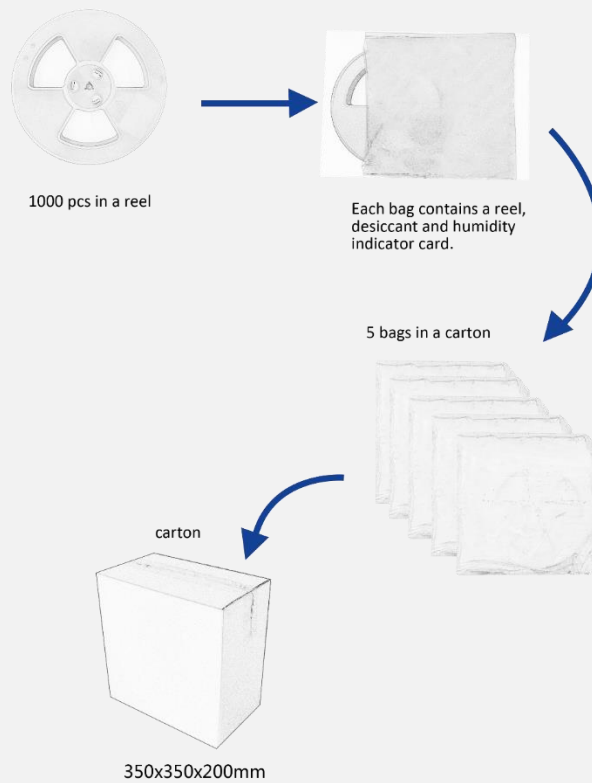

Figure 9 Packaging

7.2 Storage

In order to prevent moisture intake and protect against electrostatic discharge, TAU1302 is packaged together with a humidity indicator card and desiccant to absorb humidity.

7.3 ESD Handling

7.3.1 ESD Handling Precautions

TAU1302 which contains highly sensitive electronic circuitry is an Electrostatic-sensitive Device (ESD). Observe precautions for handling! Failure to observe these precautions may result in severe damage to the GNSS module!

- Unless there is a galvanic coupling between the local GND (i.e. the workbench) and the PCB GND, then the first point of contact when handling the PCB must always be between the local GND and PCB GND.
- Before mounting an antenna patch, connect ground of the device.
- When handling the RF pin, do not come into contact with any charged capacitors and be careful when contacting materials that can develop charges (e.g. patch antenna ~ 10 pF, coax cable $\sim 50 - 80$ pF/m, soldering iron, ...)
- To prevent electrostatic discharge through the RF input, do not touch any exposed antenna area. If there is any risk that such exposed antenna area is touched in non ESD protected work area, implement proper ESD protection measures in the design.
- When soldering RF connectors and patch antennas to the receiver's RF pin, make sure to use an ESD safe soldering iron (tip).



7.3.2 ESD protection measures

The GNSS positioning module is sensitive to static electricity. Whenever handling it, particular care must be exercised to reduce the risk of electrostatic charges. In addition to standard ESD safety practices, the following measures should be taken into account.

- Adds ESD Diodes to the RF input part to prevent electrostatics discharge.
- Do not touch any exposed antenna area.
- Adds ESD Diodes to the UART interface.

7.3.3 Moisture sensitivity level

The Moisture Sensitivity Level (MSL) of the GNSS module is MSL3.

8 REVISION HISTORY

Revision	Date	Author	Status / Comments
V1.0	2019-09-09	Vita Wu	First released
V1.1	2019-10-14	Vita Wu	Updates dimensions; Adds packaging info; Updates backup voltage descriptions and reference design diagram. Adds PCB packaging info in Section 6.
V1.2	2019-12-9	Vita Wu	Updates antenna gain in Section 4.2; Updates Section 6.3;
V1.3	2020-02	Vita Wu	Updates Galileo E6 support in section 1.6 GNSS Reception;



ALLYSTAR



www.allystar.com



info.gnss@allystar.com



5F, Building No.4, Winlead Intelligent Park, No.3, FaDa road (middle), Bantian Subdistrict, LongGang District, Shenzhen City, Guangdong Province, China.

